

Digital Amplifier Ultrasonic Sensor E4C-UDA

CSM_E4C-UDA_DS_E_7_1

Compact, Cylindrical Reflective Ultrasonic Sensor with Easy Setting

- Stable operation for a variety of objects regardless of color, transparency, or material (metallic or non-metallic).
- Compact M18-sized cylindrical Head.
Product lineup includes Side-view Heads.
- Check the sensing object distance and sensing position (i.e., threshold) on the digital display.
- Easily make settings for workpiece presence/absence and elimination of background influence by using teaching.
- Amplifiers include models with analog outputs.



 Be sure to read *Safety precautions* on page 3.

Ordering Information

Sensor

Sensor Heads (Refer to Dimensions on page 4.)

Shape	Model	Measurement range	Model
M18	Straight	50 to 300 mm	E4C-DS30
	Side view		E4C-DS30L
	Straight	70 to 800 mm	E4C-DS80
	Side view		E4C-DS80L
	Straight	90 to 1000 mm	E4C-DS100

Note: Refer to the definition of resolution in the *Ratings and Specifications* tables for information on conditions required to achieve this resolution.

Amplifiers (Refer to Dimensions on page 4.)

Shape	Power supply	Output specifications	Model
	DC	NPN output	E4C-UDA11
			E4C-UDA11AN
		PNP output	E4C-UDA41
			E4C-UDA41AN

Accessories (Order Separately)

Mounting Bracket (Refer to E39-L, F39-L, E39-S, and E39-R.)

A Mounting Bracket is not provided with the Amplifier Unit. Order a Mounting Bracket separately if required.

Appearance	Model	Quantity
	E39-L143	1

End Plate (Refer to PFP-□.)

An End Plate is not provided with the Amplifier Unit. Order an End Plate separately if required.

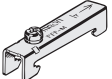
Appearance	Model	Quantity
	PFP-M	1

Ratings and Specifications

Sensor Heads

Item	Model	E4C-DS30	E4C-DS30L	E4C-DS80	E4C-DS80L	E4C-DS100
Measurement range		50 to 300 mm		70 to 800 mm		90 to 1,000 mm
Standard sensing object		100 × 100 mm SUS flat plate				
Near distance dead band		0 to 50 mm		0 to 70 mm		0 to 90 mm
Ultrasonic oscillation frequency		Approx. 390 kHz		Approx. 255 kHz		
Response speed *		30 ms		100 ms		125 ms
Ambient temperature range		Operating: -25 to +70°C, Storage: -40 to +85°C (with no icing or condensation)				
Ambient humidity range		Operating and storage: 35% to 85% (with no condensation)				
Enclosure rating		IP65				
Indicator		(Yellow) Lit: Sensor within sensing range		(Yellow) Lit: Sensor within sensing range (Green) Lit: Power indicator		(Yellow) Lit: Sensor within sensing range
Weight		Approx. 150 g				Approx. 170 g
Materials		Case: Nickel-plated brass, Oscillator surface: Glass epoxy resin and polyurethane				
Accessories		Instruction Manual, XS2F-D523-D80-A (Cable length: 2 m), XN2A-1430				

* This value is the average number of operations set to 256.

Amplifiers

Item	Model Type	E4C-UDA11	E4C-UDA41	E4C-UDA11AN	E4C-UDA41AN
		Twin Output Models		Analog Output Models	
Output configuration		NPN output	PNP output	NPN output	PNP output
Connection method		Pre-wired			
Supply voltage		12 to 24 VDC ±10%, ripple 10% max.			
Current consumption		80 mA max.			
Control output		NPN open collector (26.4 VDC max.), Load current: 50 mA max., Residual voltage: 1 V max.			
Timer		OFF/OFF-delay/ON-delay/one-shot			
Timer time		1 ms to 5 s			
Analog output	Connected load	---		Voltage output (1 to 5 VDC)	
	Output form	---		10 kΩ min.	
	Temperature characteristics	---		0.3% F.S./°C	
	Resolution	---		2.0% F.S. *	
	Linearity	---		Within ±2% F.S.	
Protective circuit		Power supply reverse polarity protection, output short-circuit protection			
Ambient temperature range		Operating: -25 to +55°C, Storage: -30 to +70°C (with no icing or condensation)			
Ambient humidity range		Operating and storage: 35% to 85% (with no condensation)			
Insulation resistance		50 MΩ min. (at 500 VDC)			
Dialectic strength		1,000 VAC, 50/60 Hz for 1 min			
Vibration resistance		10 to 150 Hz, 0.75-mm double amplitude, 80 min each in X, Y, and Z directions			
Shock resistance		500 m/s ² , 3 times each in X, Y and Z directions			
Enclosure rating		IP 50			
Materials		Case: PBT (polybutylene terephthalate), Cover: Polycarbonate			
Weight (packed state)		Approx. 150 g			
Accessories		Instruction Manual			

* Value one hour after the product is turned ON. External disturbances, however, sometimes cause minute outputs.

I/O Circuit Diagrams

E4C-UDA11 (NPN)

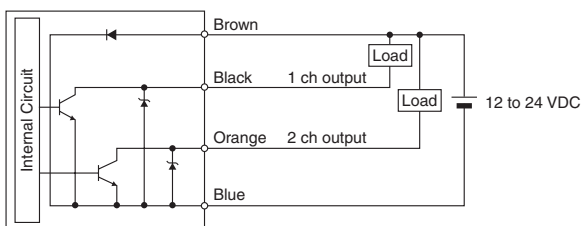

E4C-UDA41 (PNP)

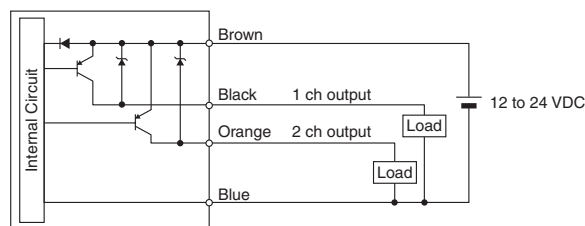

E4C-UDA11AN (NPN)

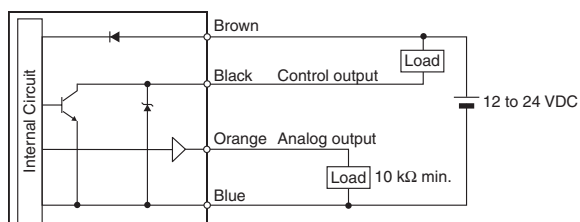

E4C-UDA41AN (PNP)

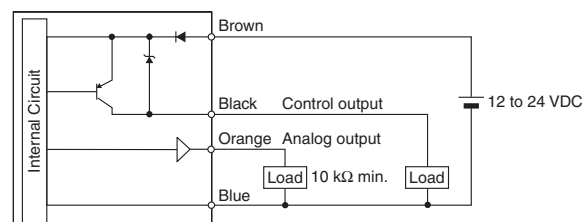

Safety precautions

Refer to *Warranty and Limitations of Liability*.

WARNING

This product is not designed or rated for ensuring safety of persons either directly or indirectly. Do not use it for such purposes.



Precautions for Correct Use

Do not use the product in atmospheres or environments that exceed product ratings.

- Separate the Sensor wiring from power supply and high-voltage lines. If Sensor wiring is placed together with or in the same duct as power supply or high-voltage lines, inductance may cause malfunction or damage to the Sensor.
- The extended cable length must be no more than 10 m. To extend the cable length, use 0.3 mm² cable.
- Detection will be possible 200 ms or longer after the power supply is turned ON. If separate power supplies are used for the load and the Sensor, turn ON the power supply to the Sensor first.
- Make sure that the cover to the Amplifier is in place before using the Sensor.
- If a writing error occurs (ERR/EEP will flash on the display) due to noise resulting from turning OFF the power supply, static electricity, or other cause, initialize the settings using the SET switch on the Amplifier.
- Depending on the application environment, some time may be required for the displayed distance to stabilize after turning ON the power supply.
- Output pulses may be generated when the power supply to the Amplifier is turned OFF. Turn OFF the load or the power supply to the load before turning OFF the Sensor.
- Do not use thinners, benzene, acetone, kerosene, or any other petroleum solvents to clean the Sensor or Amplifier.
- Turn OFF the power supply before connecting or disconnecting the Sensor Head.
Use only an E4C Sensor Head. The product may be damaged if any other Sensor Head is connected.
- The distance displayed on the Amplifier may be different from values obtained with tape measures or other devices. To adjust the displayed distance, use the scaling function.

Dimensions

(Unit: mm)
Tolerance class IT16 applies to dimensions in this data sheet unless otherwise specified.

Sensor Heads

E4C-DS30
E4C-DS80

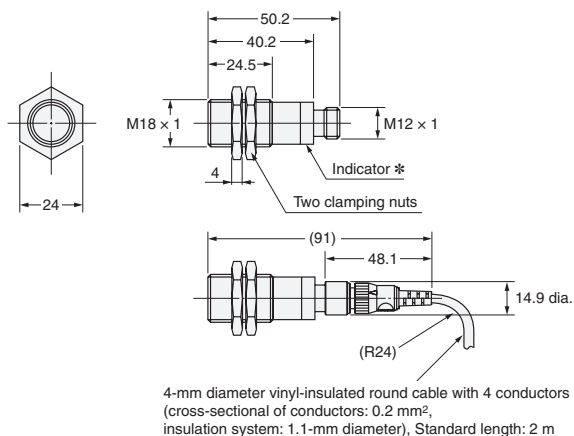

* E4C-DS30: Sensor within sensing range (Yellow)
E4C-DS80: Sensor within sensing range (Yellow), Power indicator (Green)

E4C-DS30L
E4C-DS80L

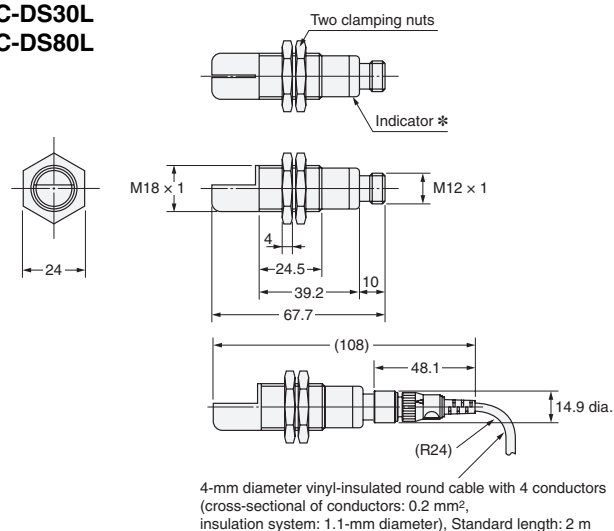

* E4C-DS30L: Sensor within sensing range (Yellow)
E4C-DS80L: Sensor within sensing range (Yellow), Power indicator (Green)

E4C-DS100

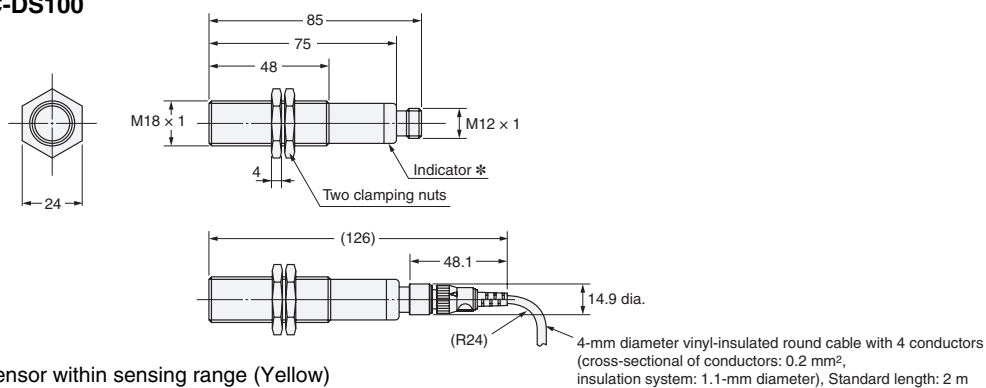

Amplifiers

E4C-UDA11
E4C-UDA41

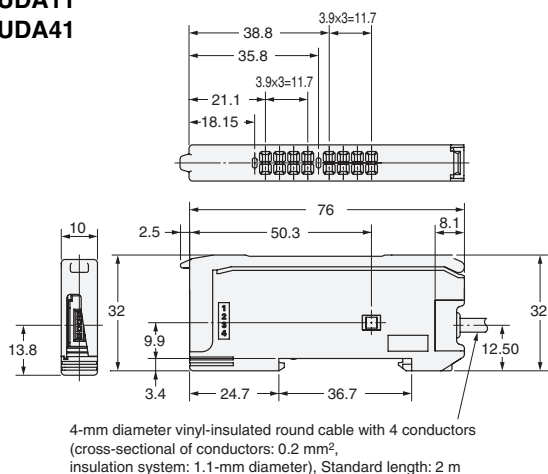

E4C-UDA11AN
E4C-UDA41AN

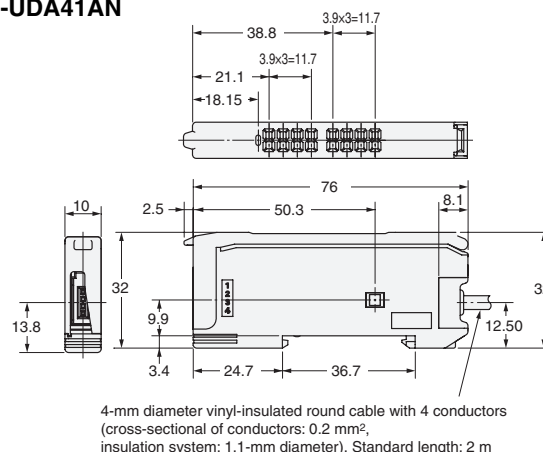

Read and Understand This Catalog

Please read and understand this catalog before purchasing the products. Please consult your OMRON representative if you have any questions or comments.

Warranty and Limitations of Liability

WARRANTY

OMRON's exclusive warranty is that the products are free from defects in materials and workmanship for a period of one year (or other period if specified) from date of sale by OMRON.

OMRON MAKES NO WARRANTY OR REPRESENTATION, EXPRESS OR IMPLIED, REGARDING NON-INFRINGEMENT, MERCHANTABILITY, OR FITNESS FOR PARTICULAR PURPOSE OF THE PRODUCTS. ANY BUYER OR USER ACKNOWLEDGES THAT THE BUYER OR USER ALONE HAS DETERMINED THAT THE PRODUCTS WILL SUITABLY MEET THE REQUIREMENTS OF THEIR INTENDED USE. OMRON DISCLAIMS ALL OTHER WARRANTIES, EXPRESS OR IMPLIED.

LIMITATIONS OF LIABILITY

OMRON SHALL NOT BE RESPONSIBLE FOR SPECIAL, INDIRECT, OR CONSEQUENTIAL DAMAGES, LOSS OF PROFITS OR COMMERCIAL LOSS IN ANY WAY CONNECTED WITH THE PRODUCTS, WHETHER SUCH CLAIM IS BASED ON CONTRACT, WARRANTY, NEGLIGENCE, OR STRICT LIABILITY.

In no event shall the responsibility of OMRON for any act exceed the individual price of the product on which liability is asserted.

IN NO EVENT SHALL OMRON BE RESPONSIBLE FOR WARRANTY, REPAIR, OR OTHER CLAIMS REGARDING THE PRODUCTS UNLESS OMRON'S ANALYSIS CONFIRMS THAT THE PRODUCTS WERE PROPERLY HANDLED, STORED, INSTALLED, AND MAINTAINED AND NOT SUBJECT TO CONTAMINATION, ABUSE, MISUSE, OR INAPPROPRIATE MODIFICATION OR REPAIR.

Application Considerations

SUITABILITY FOR USE

OMRON shall not be responsible for conformity with any standards, codes, or regulations that apply to the combination of products in the customer's application or use of the products.

At the customer's request, OMRON will provide applicable third party certification documents identifying ratings and limitations of use that apply to the products. This information by itself is not sufficient for a complete determination of the suitability of the products in combination with the end product, machine, system, or other application or use.

The following are some examples of applications for which particular attention must be given. This is not intended to be an exhaustive list of all possible uses of the products, nor is it intended to imply that the uses listed may be suitable for the products:

- Outdoor use, uses involving potential chemical contamination or electrical interference, or conditions or uses not described in this catalog.
- Nuclear energy control systems, combustion systems, railroad systems, aviation systems, medical equipment, amusement machines, vehicles, safety equipment, and installations subject to separate industry or government regulations.
- Systems, machines, and equipment that could present a risk to life or property.

Please know and observe all prohibitions of use applicable to the products.

NEVER USE THE PRODUCTS FOR AN APPLICATION INVOLVING SERIOUS RISK TO LIFE OR PROPERTY WITHOUT ENSURING THAT THE SYSTEM AS A WHOLE HAS BEEN DESIGNED TO ADDRESS THE RISKS, AND THAT THE OMRON PRODUCTS ARE PROPERLY RATED AND INSTALLED FOR THE INTENDED USE WITHIN THE OVERALL EQUIPMENT OR SYSTEM.

PROGRAMMABLE PRODUCTS

OMRON shall not be responsible for the user's programming of a programmable product, or any consequence thereof.

Disclaimers

CHANGE IN SPECIFICATIONS

Product specifications and accessories may be changed at any time based on improvements and other reasons.

It is our practice to change model numbers when published ratings or features are changed, or when significant construction changes are made. However, some specifications of the products may be changed without any notice. When in doubt, special model numbers may be assigned to fix or establish key specifications for your application on your request. Please consult with your OMRON representative at any time to confirm actual specifications of purchased products.

DIMENSIONS AND WEIGHTS

Dimensions and weights are nominal and are not to be used for manufacturing purposes, even when tolerances are shown.

PERFORMANCE DATA

Performance data given in this catalog is provided as a guide for the user in determining suitability and does not constitute a warranty. It may represent the result of OMRON's test conditions, and the users must correlate it to actual application requirements. Actual performance is subject to the OMRON Warranty and Limitations of Liability.

ERRORS AND OMISSIONS

The information in this document has been carefully checked and is believed to be accurate; however, no responsibility is assumed for clerical, typographical, or proofreading errors, or omissions.

2011.9

In the interest of product improvement, specifications are subject to change without notice.

OMRON Corporation
Industrial Automation Company

<http://www.ia.omron.com/>

(c)Copyright OMRON Corporation 2011 All Right Reserved.